

ENCORE^{wb} by ABEL

PIANO PRODUCTS
Brooks LTD



(800) 326-2440

BrooksLTDonline.com

DAMPP-CHASER - WNG

BOLDUC - TOKIWA

CUSTOM SERVICES

PRODUCTS & SERVICES CATALOG

Brooks LTD Piano Products, LLC

SERVING PIANO REBUILDERS AND TECHNICIANS SINCE 1980



An updated version of our catalog
is always available online!
www.BrooksLTDonline.com

TABLE OF CONTENTS

BROOKS LTD SERVICES 4-5

- Project Consultation
- Custom Shanks & Flanges
- Grand Hammers
 - Boring, Tapering & Tail Shaping
 - Full Side Hammer Tapering
 - Prehanging
 - Weight Analysis & Duplication
- Upright Hammers
 - Boring & Tapering
 - Shanking
- Wippen Assembly

ENCORE^{wb} HAMMERS 6-7

by The Abel Hammer Company

- Natural Felt 6-7
- Grand 7
- Upright 7

GRAND ACTION PARTS 8-18

ENCORE^{wb}

- Shanks & Flanges 9-10
- Wippens 10
- TOKIWA**
- Backchecks 11
- Damper Action Replacement Parts 17
- Damper Felt & Kits 13
- Grand Wippens, Heels & Flanges 12-16
- Hammer Rest Rail Nuts & Bolts 13
- Knuckles 11
- Shanks & Flanges 11

WESSELL, NICKEL & GROSS

- Shanks & Flanges 18
- Wippens & Back Action 18

UPRIGHT ACTION PARTS 19-22

by Tokiwa

- Upright Action Parts 22
- Upright Butts & Flanges 19
- Upright Damper Kit & Flanges 22
- Steinway Type Upright Action Parts 20-21

BOLDUC WOOD PRODUCTS 23-25

- Bridge Capping Material 24
- Drill Bits 23
- Pinblock Extractors 23
- Pinblock Panels 24
- Rib Stock 24
- Sounding Board Panels, Trim & Molding 25
- Touchweight Scale 23
- 3-in-One Voicing Tool 23

DAMPP-CHASER PRODUCTS 26

- Piano Life Saver Systems 26
- Replacement Products & Supplies

F.A.Q. 27

ORDER FORM 28

TERMS & POLICIES 30



**WE ARE HERE TO HELP YOU ACHIEVE
YOUR BEST RESULTS AS A PIANO TECHNICIAN!**

(800) 326-2440 ■ BrooksLTD@sbcglobal.net

Monday - Friday 8:30a - 3:30p EST
www.BrooksLTDonline.com

Brooks LTD was established in 1980 as an answer to technicians' demand for quality replacement piano products, and honest, experienced technical support. We at Brooks LTD are dedicated craftspeople committed to the piano service industry. Constant demand on the quality of our service and materials assures full confidence in the products you receive. Contact us at anytime with your questions and comments. Our success is defined by those we serve!

“We value your business because we value what you do.”

Our success is defined by those we serve. As a business, not only are we responsible for meeting your needs as a valued technician, we are responsible for providing the support that will allow you to perform to the absolute best of your ability.

Our goal is to collaborate with you - the piano technician, the rebuilder, the business owner - to service and restore instruments to their finest by providing consistent quality and innovation in our specialized products. Brooks LTD offers accurate, trustworthy service from well-trained specialists who are here to support you. In appreciation of music, and the use of the piano, we aim to gain your full confidence in the products you receive and in the personalized, honest service we provide. We look forward to working with you to complete your next project.

Melanie



BROOKS LTD SERVICES

Project Consultation ▪ Prehung Hammers ▪ Boring, Tapering & Tail Shaping
Weight Analysis & Duplication ▪ Custom Shanks & Flanges ▪ Wippen Assembly

ENCORE^{wb} ACTION PARTS

Hammers ▪ Shanks & Flanges ▪ Wippens

BOLDUC WOOD PRODUCTS

Sounding Boards ▪ Pinblocks ▪ Ribstock
Bridge Capping Material ▪ Molding & Shims ▪ Tools

TOKIWA ACTION PARTS

Shanks & Flanges ▪ Wippens ▪ Grand & Upright Action Parts
Back Actions ▪ Damper Felt

WESSELL, NICKEL & GROSS ACTION PARTS

Shanks & Flanges ▪ Wippens ▪ Back Actions

DAMPP-CHASER PIANO LIFE SAVER SYSTEMS

A full line of Humidity Control Systems & Products

“Quality products for the discriminating technician”

Brooks LTD is a wholesale distributor of piano products and supplies.
We sell directly to piano technicians and rebuilders, piano dealers and universities.

Brooks LTD Piano Products

152 Route 163, Building A ▪ Uncasville, CT ▪ 06382
800.326.2440 TEL ▪ 860.848.8089 FAX ▪ BrooksLTD@sbcglobal.net
www.BrooksLTDonline.com



SERVICES

ORDERS & TECH SUPPORT
(800) 326-2440
M-F 8:30AM - 3:30PM EST

WEIGHT ANALYSIS & DUPLICATION
Optimize touch and playability

CUSTOM SHANKS & FLANGES
*Bored, cut and tapered to samples
Complimentary on ENCORE^{nb} product*

PREHUNG HAMMERS
Available on new or existing shanks & flanges

BORE, TAPER & TAIL SHAPING
Custom hammer drilling and shaping

FULL SIDE HAMMER TAPERING
Top to bottom taper for weight control

WIPPEN ASSEMBLY
Flanges pinned and heels glued, services separate

Bore, Taper & Tail Shaping

BORED TO FACTORY SPECIFICATIONS

Hammers may be bored to factory specifications without samples for most pianos by the following manufacturers:

STEINWAY • MASON & HAMLIN
KAWAI • BALDWIN

BORED TO YOUR SPECIFICATIONS

For a project bored to your specifications, please contact us for a Bore Specification Guide Sheet and instructions. Always speak with a technician to confirm your order.

TIED TO A CERTAIN PRODUCT?

We are here to help you do your best work. If that work requires using product that we do not carry have your products shipped directly to us & our service department will provide you with custom hammer duplication & pre-hanging.

For details give us a call!

800-326-2440

BORED TO SAMPLES

For *GRAND PIANOS*, send the following:

- First & last hammer of each section attached to shank
- First straight bore (90°) hammer, if not at a break
- Hammer #71 if being prehung
- Desired shank diameter
- Weight concerns

For *UPRIGHT PIANOS*, send the following:

- First & last hammer of each section attached to shank
- Last angled hammer
- First straight bore (90°) hammer, if not at a break
- Desired shank diameter

FOR ALL ORDERS

Send samples still attached to shanks, and include:

- Name, address, telephone number & email
- REMEMBER TO NUMBER EACH HAMMER!
Please note the following on your order:
- Piano make, model, size and serial number
- Weight concerns
- Desired bore diameter

SERVICES

PROJECT ANALYSIS - We're here to make your work easier!

Brooks LTD specializes in products and services that make your restoration more efficient. Our expert staff will help you select the best parts for your project, analyze, customize, and even help troubleshoot installation challenges.



Weight Analysis & Duplication

Brooks LTD's philosophy is to restore your instrument as close to original dimensions as possible. We work directly with you to optimize weight control and playability by selecting hammers, shanks and flanges to best suit your project. If touchweight or geometry is a concern for your instrument, we will assist you in customizing replacement hammers and knuckle placement for best results.

TECH TIP: Move a bass hammer to the first tenor, shave felt from the shoulders until you obtain the ideal touchweight, send us the sample or use our digital scale to weigh the hammer. We will use the result to target the correct hammer weight for your set.

BROOKS LTD TOUCHWEIGHT KIT



This useful touchweight kit is great for determining parts selection and weight targets for your action replacement. ITEM BR-TWK

Prehung Hammers

GRAND PIANOS

- ▶ Select your *ENCORE^{wb}* Grand hammers (page 7)
- ▶ Select your new Shanks & Flanges (pages 9-11 & 18)
- ▶ If weight is a concern, include the desired weights of the first bass and first tenor hammers OR send downweight information together with your samples.



UPRIGHT PIANOS

- ▶ Select *ENCORE^{wb}* Upright hammers (page 7)
- ▶ Our standard shank diameter is 5.8mm to fit new Tokiwa Upright Butts (p.19). If you are using existing or original butts, confirm that the shank diameter is appropriate for your parts.



Brooks LTD provides custom hammer selection and service consultation with each project we receive.

Samples are always best to determine the correct hammer size and weight for your project.

Please include first and last hammer shank assembly from each section.

Call (860) 326-2440 to discuss your project with a technician.



PIANO HAMMERS

ENCORE^{wb} Natural Felt Hammers, identifiable by our trademark burgundy underfelt, are pressed in unheated cauls to eliminate wool fiber damage for exceptional consistency and resilience.

ABEL ENCORE^{wb} NATURAL FELT

ENCORE^{wb} Hammers are of the finest quality workmanship, designed with the technician in mind, pre-filed and easily voiced. They produce a strong, round bass, and a clear tenor/treble without the "bite" often associated with European and Asian pianos. ENCORE^{wb} Natural Felt hammers are very consistent with immediate tone out of the package requiring little voicing. They are easily voiced up or down, and react quickly to normal filing, needling and the use of light chemicals to bring them to their optimum performance. ENCORE^{wb} Natural Felt hammers are available for Grand and Upright pianos, in several models and dimensions to meet the specific needs of each instrument and performance situation.

WHAT IS NATURAL FELT?

From 2003-2006 The Abel Hammer Company participated in *The Biofelt Project*, a green initiative funded by the European Union to evaluate the process of felt making. The aim of *The Biofelt Project* was to determine the qualities of felt in industry use, to discover ways to reduce damage to wool fibers during processing, and to develop new and better felt qualities using eco-friendly methods. Using research and techniques learned from *The Biofelt Project*, *Natural Felt* was developed in 2006 using high quality merino wool and eco-friendly cleaning methods in contrast to standard modern felt manufacturing which uses a series of acid baths called carbonization to remove foreign matter to produce a clean white look to the felt. The changes made in the felt process maintain more of the natural wool color, and original lanolin and oils, proven to increase resilience in the felt, producing a very desirable hammer tone and ease of voicing.

HAMMER WEIGHT: Size and pound classifications are used industry-wide to identify the finished size and density of various hammer felts available on the market. Size and weight classifications help to determine a starting point when making your hammer selection. The Abel Hammer Factory produces hammers using four different sizes of felt 3,4,5,6. The size is determined by the size of the felt on the bass end of the hammer strip as indicated below. These sizes correlate to US terms as follows 3=14lb 4=15lb 5=17lb 6=19 lb - see *hammer selections on opposing page*.

ABEL FELT SIZES

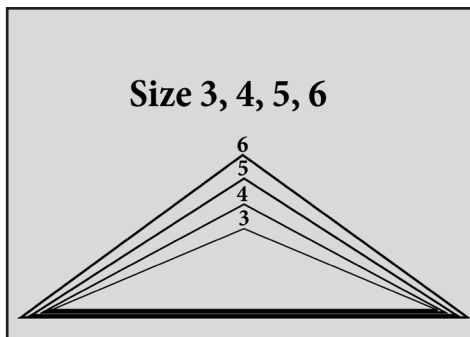

FELT SIZE	POUND	FINISHED WEIGHT	
		BASS	TENOR
3	14lb	8gr	7gr
4	15lb	9gr	8gr
5	17lb	9.5gr	8.5gr
6	19lb	10gr	9gr

Turn around time is typically 4 working days from receipt of your samples. Completed orders are shipped via UPS Ground or UPS 3-day West of the Mississippi and by US Mail Priority Express to Canada. For details, see our POLICIES & TERMS (page 30).

PIANO HAMMERS

It's easy to order! Call (800) 326-2440 or email BrooksLTD@sbcglobal.net
Use the ORDER FORM (p. 28) in this catalog, or print forms and guides online!



ABEL ENCORE^{wb} Natural Felt Grand Hammers

"The Technician's Choice" - ENCORE^{wb} Natural Felt provides immediate tone, resilience and flexibility. Natural Felt wool fibers are cleaned without harsh chemicals, retaining the wool's natural color, lanolin and oils. Our most versatile hammer, with excellent wear resistance and minimum brightening with heavy use. T-rivet reinforcement.

MODEL	WEIGHT	WIDTH	OVERALL LENGTH		WOOD
			Bass	Tenor/Treble	
EH141N	size 3 / 14lb	10.5mm	3 5/16" (84mm)	3" (77mm)	Walnut
EH142N	size 3 / 14lb	10.5mm	3 3/16" (81mm)	2 13/16" (72mm)	Walnut
EH143N	size 3 / 14lb	10.5mm	3 7/16" (88mm)	3 1/8" (80mm)	Walnut
EH171N	size 5 / 17lb	11mm	3 5/16" (84mm)	3" (77mm)	Walnut
EH172N	size 5 / 17lb	11mm	3 3/16" (81mm)	2 13/16" (72mm)	Walnut
EH173N	size 5 / 17lb	11mm	3 7/16" (88mm)	3 1/8" (80mm)	Walnut
EH174N	size 5 / 17lb	11mm	3 7/16" (88mm)	3 7/16" (88mm)	Walnut
EH191N	size 6 / 19lb	11.5mm	3 5/16" (84mm)	3" (77mm)	Hornbeam
EHCN	size 6 / 19lb	11.5mm	3 1/4" (83mm)	2 15/16" (75mm)	Walnut

ABEL ENCORE^{wb} Upright Hammers

ENCORE^{wb} Upright hammers are designed with the same felt construction as our ENCORE^{wb} Classic and Natural Felt grand hammers. The ENCORE^{wb} Series has quality hammers for all full size, spinet, console or studio uprights. T-rivet reinforcement on 15lb hammers. Staple reinforcement on 14lb hammers.

MODEL	WEIGHT	WIDTH	OVERALL LENGTH		WOOD
			Bass	Tenor/Treble	
EHU 60-68	size 4 / 15lb	10.5mm	2 3/8" (60mm)	2 11/16" (68mm)	Mahogany
EHU 65-73	size 4 / 15lb	10.5mm	2 9/16" (65mm)	2 7/8" (73mm)	Mahogany
EHU 67-75	size 3 / 14lb	9.5mm/10.5mm	2 5/8" (67mm)	2 15/16" (75mm)	Hornbeam
EHU 66-77N	size 4 / 15lb	10mm	2 5/8" (66mm)	3 1/16" (77mm)	Mahogany

ENCORE^{wb} Natural Felt has received rave reviews from technicians in the field. Easily voiced, resilient and long-lasting, these hammers are the hands-on technician's choice especially coupled with an efficient installation of prehung hammers - a Brooks LTD specialty!



GRAND ACTION PARTS

*At Brooks LTD, we strive to meet the needs of each technician, the individual piano, the artist and each performance. In that respect, we are pleased to offer a variety of grand action parts from various manufacturers including:
The Abel Hammer Company, Tokiwa and Wessell Nickel & Gross.*

ABEL ENCORE^{wb} Action Parts "The Technician's Choice"

ENCORE^{wb} Action Parts are a specifically designed selection of Hammers (p. 7), Shanks & Flanges and Wippens (p. 9-10) manufactured to Brooks LTD's strictest specifications by The Abel Hammer Company.

ENCORE^{wb} replacement Action Parts include maple shanks & flanges designed and produced to the closest possible engineering dimensions for most grand pianos, and wippens for Steinway grand pianos. ENCORE^{wb} products are manufactured using the highest quality materials, exceptional woodworking and consistent hand-pinning.

TOKIWA Action Parts

We carry a complete line of the Tokiwa Action Parts. These high quality grand action replacement parts are made of hornbeam and are bushed with the finest quality "White Core" bushing cloth. Accurate specifications allow for replacement on most grand pianos and several universal type parts are available for customization.

WESSELL, NICKEL & GROSS Action Parts

We are pleased to include a selection of Wessell, Nickel & Gross action parts to complement our existing products and services. We have the ability to custom order to meet most needs.

WNG action parts offer an alternative to traditional wooden action parts. WNG's nylon composite material starts with a base made of a type of plastic which is strong but too flexible. The base is paired with a carbon fiber that adds needed rigidity. The result is a material similar to metal alloys providing stability and consistency.

LOOKING FOR A CERTAIN PRODUCT? We are here to help you do your best work. If you don't see what you need call us. If your work requires action parts that we do not carry we can work together with you to find it. Send your parts to us, we are happy to pair our hammers with your parts and provide you with quality services. For details give us a call! 800-326-2440

*Our success is measured by your results. Let us know about your experience using our products.
Your feedback helps us to continually improve our products and service.*

Write to us! BrooksLTD@sbcglobal.net

GRAND ACTION PARTS

Brooks LTD's ENCORE^{wb} Series shanks & flanges are manufactured by **The Abel Hammer Company**, available in a variety of styles, widths and sizes to allow the closest match to existing parts, or to aid in controlling keyweight and touch.









ABEL ENCORE^{wb} Shanks & Flanges

ENCORE^{wb} shanks are made with exceptional Bolduc maple, the finest bushing cloth, authentic buckskin knuckle and hornbeam flanges; hand-bushed and pinned.

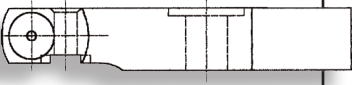
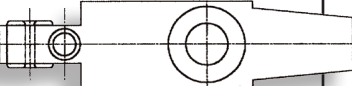
CENTER IT!

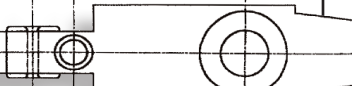
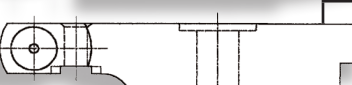
To determine the correct dimensions of your new shanks and flanges, always measure from the **CENTER** of the knuckle, center pin, drop screw or screw hole.

[Graphics may not be exact.]

MODEL ESF		MEASUREMENTS							
		center of knuckle to center of center pin	center of pin to center of drop screw	center of pin to center of screw hole	center of screw hole to back of flange	width of shank at knuckle	knuckle extension from bottom of shank	# tapered	
	A17 Many Knabe, Chickering & Others	17mm	4.5mm	23mm	19mm	11.25mm	10mm	90	
	A18 Many Knabe, Chickering & Others	18mm	4.5mm	23mm	19mm	11.25mm	10mm	90	
	AL Some Odd Grands	18mm	4.5mm	26.5mm	20mm	11.25mm	10mm	90	
	C17 Most Pratt & Read	17mm	4.5mm	25mm	20mm	12mm	10mm	90	
	C18 Mason & Hamlin, WN&G	18mm	4.5mm	25mm	20mm	12mm	10mm	90	
	KN Many Knabe (cutout flange)	16.5mm	5.5mm	24mm	16mm bottom	11.25mm	10mm	90	
	NB New Bore Baldwin (angled flange)	17mm	6mm	25mm	23mm top 21mm bottom	12mm	10mm	30	
	OB Old Bore Baldwin (angled flange)	17mm	6mm	23mm	25mm top 23mm bottom	12mm	10mm	30	
	R Most European Pianos, Baldwin Concert Grands - Renner-type	17mm	4.5mm	22.5mm	29mm	12mm	10mm	30 or 90	
	Y Yamaha, Young Chang, Many Asian imports	17mm	4.5mm	25mm	9mm	12mm	10mm	30 or 90	
	ESFRUB Custom Shanks & Flanges - European R-type unbored	16mm or 17mm	4.5mm	UNBORED		11.25mm or 12mm	9mm or 10mm	30 or 90	
	ESNF Grand Shanks for use with brass flange replacement	16mm	NO FLANGE			11.25mm	10mm	90	



GRAND ACTION PARTS

"The value of a Steinway is determined by its touch and tone."

ABEL ENCORE^{wb} Steinway Type

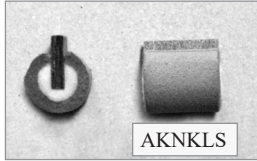

Knuckles by Abel
 9mm, 10mm or 11mm (sets only)
 10 mm Newer Steinway Type,
 wider molding

center of knuckle to center of center pin	center of pin to center of drop screw	center of pin to center of screw hole	center of screw hole to back of flange	width of shank at knuckle	knuckle extension from bottom of shank	# tapered
---	---------------------------------------	---------------------------------------	--	---------------------------	--	-----------

[Graphics may not be exact.]

MODEL		MEASUREMENTS							
	ESFS 16 Steinway, New York Original	16mm	4.5mm	23.5mm	11.5mm	12mm	10mm	90	
	ESFS 16.5 Steinway, New York Modified	16.5mm	4.5mm	23.5mm	11.5mm	12mm	10mm	90	
	ESFS 17¹⁰ Steinway, New York Modified	17mm	4.5mm	23.5mm	11.5mm	12mm	10mm	90	
	ESFS 17¹¹ Steinway, New York Modified	17mm	4.5mm	23.5mm	11.5mm	12mm	11mm	90	
	ESFS H Steinway, Hamburg	17mm	4.5mm	24.5mm	11mm	12mm	10mm	30	
	ESFS B Steinway, Boston	17mm	4.5mm	23mm	20.5mm	12mm	10mm	30	

Exclusively at Brooks LTD

ENCORE^{wb} Steinway Type Wippens by The Abel Hammer Company are manufactured of exceptional Bolduc maple, finest bushing cloth, and hornbeam flanges; hand-bushed pinned.

- ORIGINAL WEIGHT
- ORIGINAL DIMENSIONS
- BUTTERFLY SPRING
- HAND PINNED
- ANGLED HEEL

ABEL ENCORE^{wb} STEINWAY TYPE GRAND WIPPEN

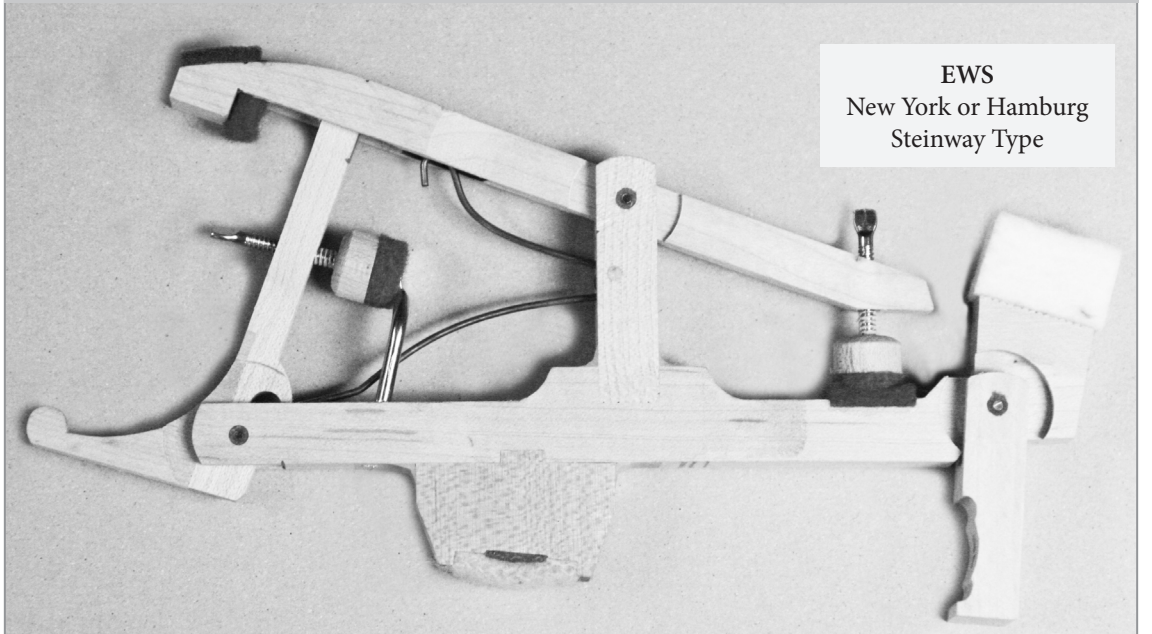

MODEL	DESCRIPTION
EWS	Steinway Type Wippen - New York or Hamburg Style

GRAND ACTION PARTS

Tokiwa Action Parts made in Japan, offer a large selection of grand action parts.
If you don't see something call us!



TOKIWA Shanks & Flanges

Tokiwa models are available in dimensions for many pianos. Hornbeam construction. Top 30 shanks tapers on all models. Escaine knuckles.

MODEL		MEASUREMENTS						
		center of knuckle to center of center pin	center of pin to center of drop screw	center of pin to center of screw hole	center of screw hole to back of flange	width of shank at knuckle	knuckle extension from bottom of shank	# tapered
TSF AN	A Type Narrow	17mm	4.5mm	23mm	19mm	11.25mm	10mm	30
TSF C	C Type	17mm	4.5mm	25mm	20mm	12mm	10mm	30
TSF KN	Knabe Narrow	17mm	4.5mm	23.5mm	15.5mm	11.25mm	10mm	30
TSF NB	New Bore Baldwin	17mm	6mm	25mm	23mm top 21mm bottom	12mm	10mm	30
TSF OB	Old Bore Baldwin	17mm	6mm	23mm	25mm top 23mm bottom	12mm	10mm	30
TSF R	Renner Type	17mm	4.5mm	22.5mm	29mm	12mm	10mm	30
TSF S	Steinway, New York	16mm	4.5mm	23.5mm	11.5mm	12mm	10mm	30
TSF Y	Yamaha/Young Chang	17mm	4.5mm	25mm	9mm	12mm	10mm	30
TSF UB	Unbored for Custom Specs	17mm	4.5mm	UNBORED		12mm	10mm	30

BACKCHECKS

TBCNW
Regular (no wire)

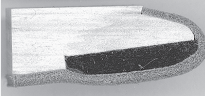

32mm

TBCSNW
Steinway (no wire)



42mm

TBC-82 Regular (82mm with wire)
TBC-91 Regular Long (91mm with wire)



TBCS Steinway (82mm with wire)



[Graphics not to measurement]

MODEL	DESCRIPTION
TBCNW	Backchecks, Regular, no wire
TBC-82	Backchecks, Regular - 82mm with wire
TBC-91	Backchecks, Regular, Long - 91mm with wire
TBCSNW	Backchecks, Steinway type, no wire
TBCS	Backchecks, Steinway type - 82mm with wire
TKNKLS	Knuckles, 10mm (set only)

TKNKLS



(10mm drop)
(sets only)

PROJECT ANALYSIS
We're here to make your work easier!
Our expert staff will help you select the best parts for your project, analyze, customize, and help troubleshoot installation challenges.

ENCORE[®] by ABEL

Brooks LTD PIANO PRODUCTS

DAMP-CHASER • WNG

BOLDUC • TOKIWA

(800) 326-2440
BrooksLTDonline.com

CUSTOM SERVICES

GRAND ACTION PARTS

Tokiwa Steinway Style grand wippens are now available with straight or angled heel.

TOKIWA Wippens for Grand Pianos

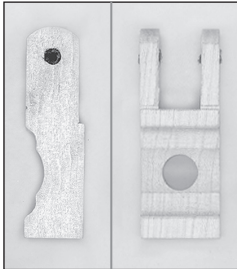

TWFS
Steinway type
Flange Only
(sets only)

[Graphics may not be exact.]

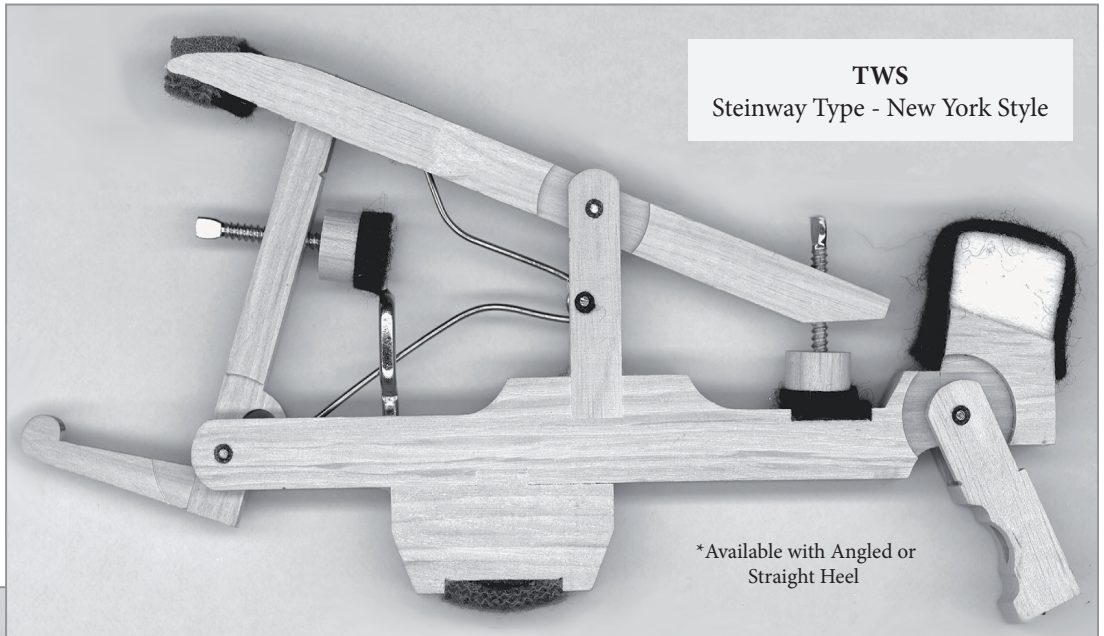

TWS
Steinway Type - New York Style

* Available with Angled or
Straight Heel

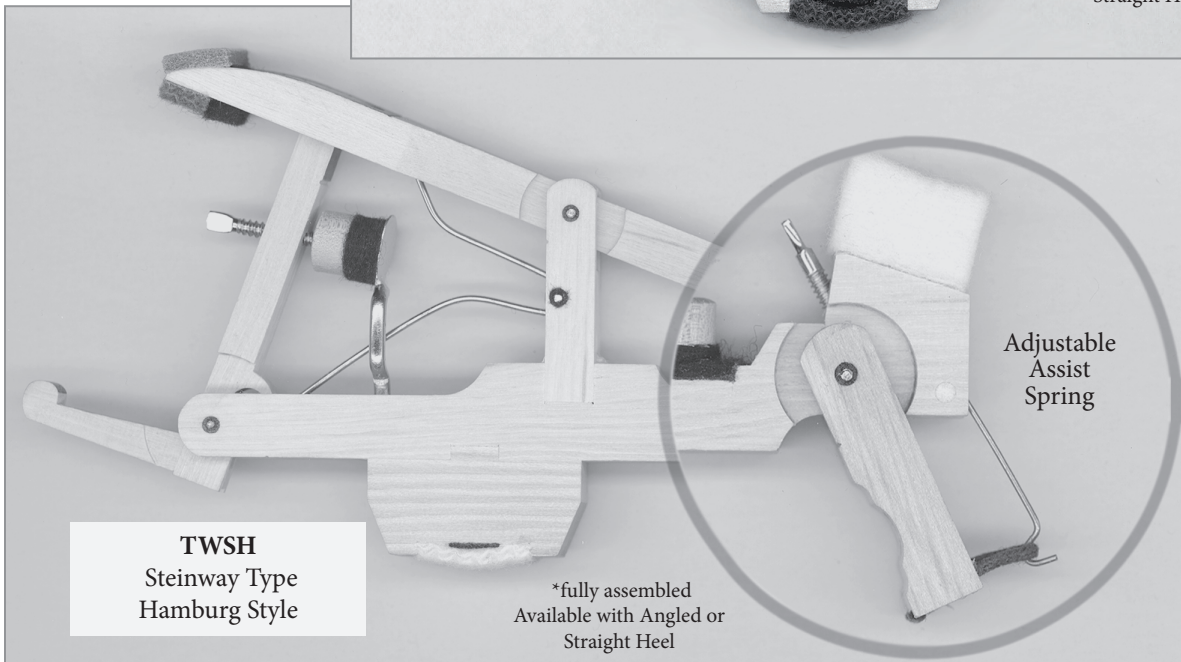

TWSH
Steinway Type
Hamburg Style

*fully assembled
Available with Angled or
Straight Heel

**STEINWAY TYPE
WIPPEN HEELS**
*Not Sold Separately

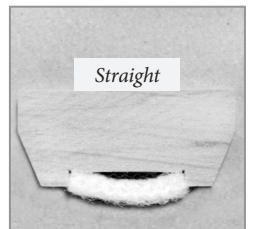
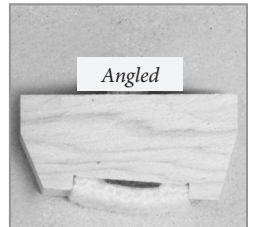

Adjustable
Assist
Spring

TOKIWA STEINWAY TYPE WIPPENS & FLANGES

MODEL	DESCRIPTION
TWS	Steinway Type Wippen, New York Style - Straight Heel (Angled Heel Available)
TWSH	Steinway Type Wippen, Hamburg Style (with adjustable assist spring) (Angled Heel Available)
TWFS	Steinway Type Wippen Flange (sets only)

GRAND ACTION PARTS

Can't find what you're looking for? We're only a phone call away!
 (800) 326-2440



TOKIWA Wippens for Grand Pianos

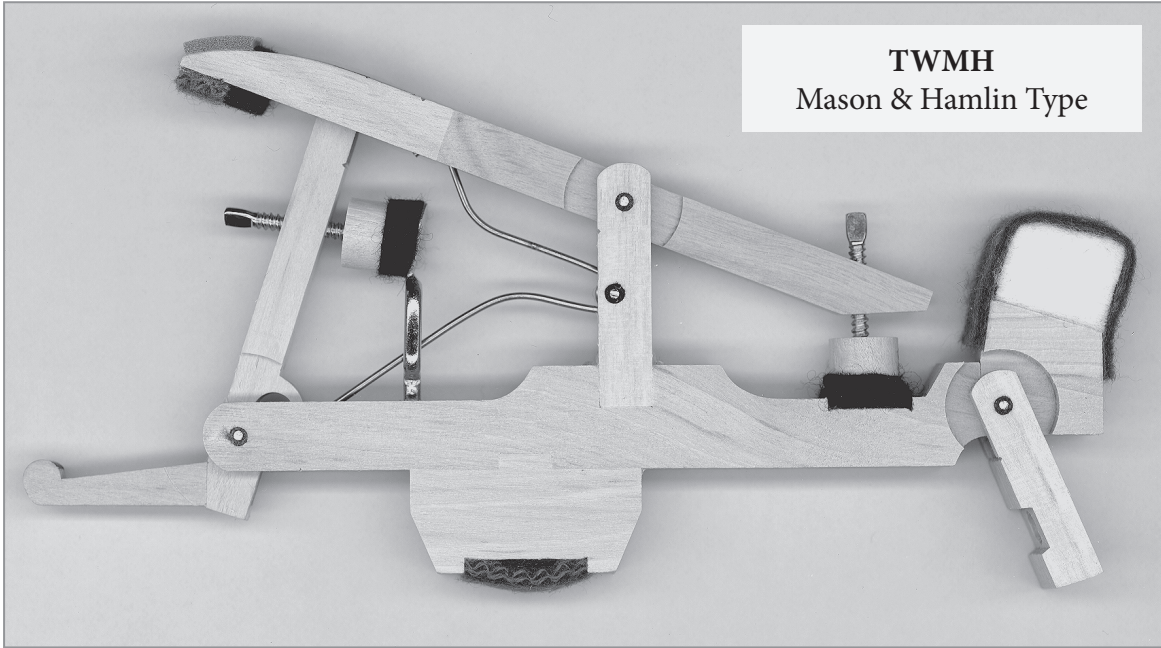

TWMH
 Mason & Hamlin Type

MODEL	DESCRIPTION
TWMH	Mason & Hamlin Type Wippen (Wessel, Nickel & Gross type)

TOKIWA Grand Action Parts

TDFK Grand Damper Felt Kit



Now available: red backed (RB) OR unbacked (UB)

MODEL	DESCRIPTION
TDFK-RB	Grand Damper Felt Kit - Red Backed
TDFK-UB	Grand Damper Felt Kit - Unbacked
THRBN	Hammer Rail Bolt & Nut Kit (set of 5)

TDFK-RB

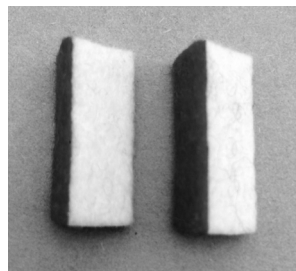

Red backed damper felt

THRBN Hammer Rail Bolt & Nut Kit



[Graphics may not be exact.]



GRAND ACTION PARTS

Universal Wippen made of hornbeam construction. TWU sets are sold with Universal Flange attached. TWUBK Sets are NOT assembled. Flanges and Heels are sold separately. (page 15)

TOKIWA WIPPENS for Grand Pianos

1. SELECT YOUR UNIVERSAL WIPPEN BODY

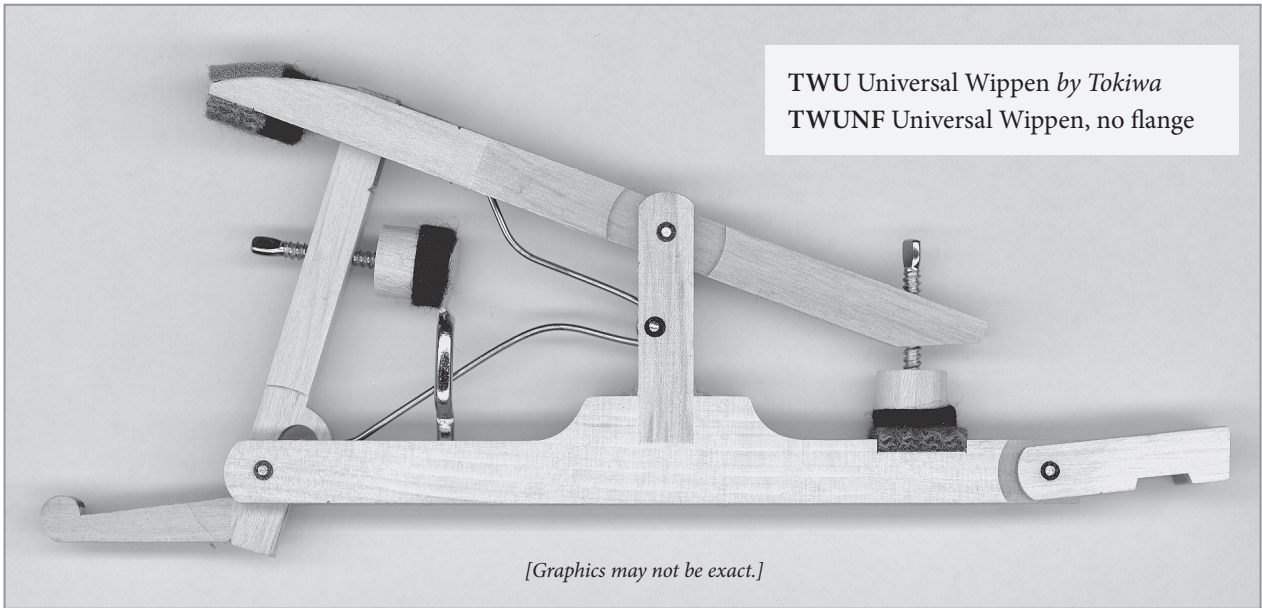

*If flange centerpin is in line with jack centerpin, use TWU or TWUNF.
If flange centerpin is 4mm above Jack centerpin, use the TWUBK body.*

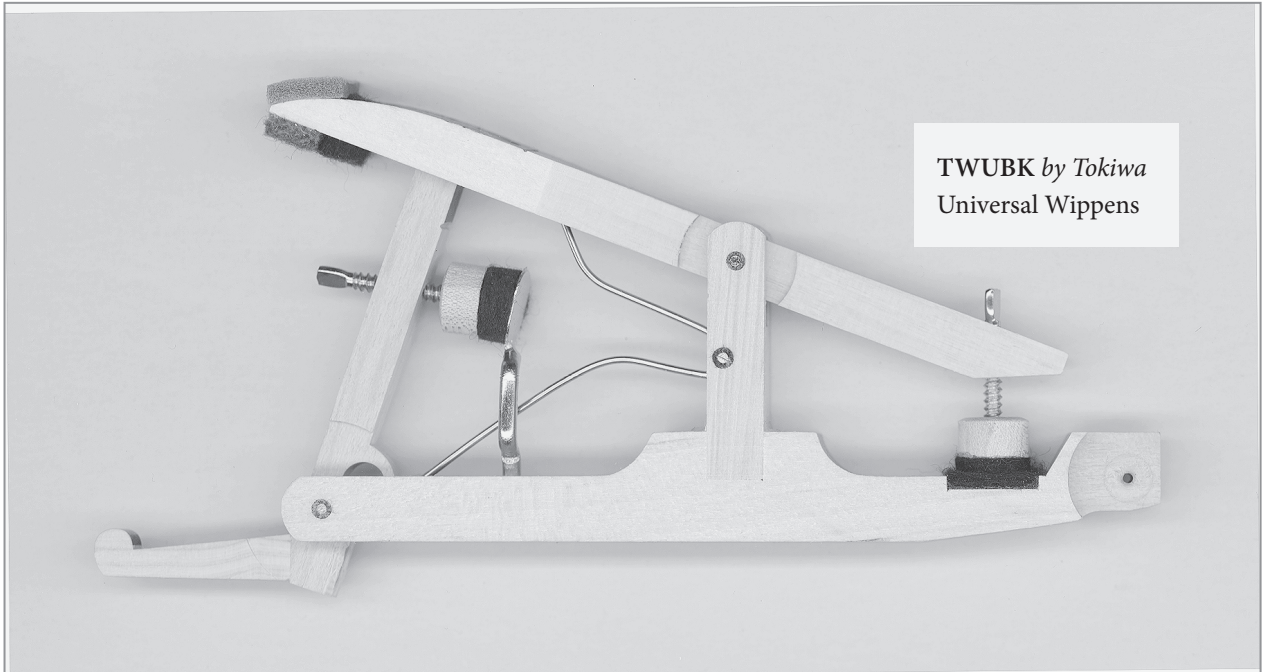

Flanges for TWUBK and TWUNF include #19 center pins. Heels must be mounted and glued on all Universal sets. Wippen assembly services are available.

GRAND ACTION PARTS

Brooks LTD's staff of technicians are ready to help you select the best products for your restoration. We offer full project consultation and action duplication services.



TOKIWA Wippens for Grand Pianos

2. SELECT YOUR UNIVERSAL WIPPEN HEEL

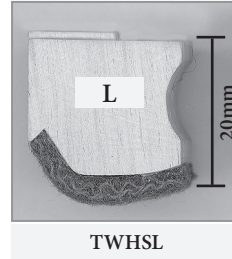
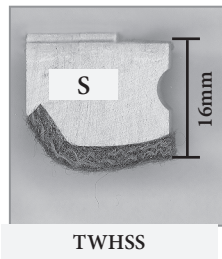
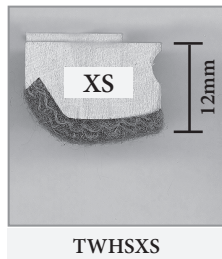

SLOTTED-TYPE
HEELS
FOR
UNIVERSAL
WIPPENS

[Graphics may not be exact.]

3. SELECT YOUR UNIVERSAL WIPPEN FLANGE

Measurement from the center of the center pin to the center of the screw hole.

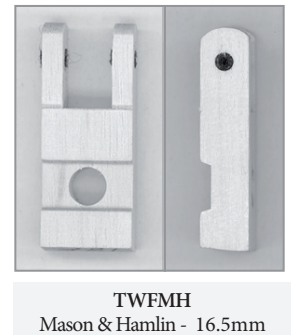

UNIVERSAL WIPPENS, FLANGES & HEELS

MODEL	DESCRIPTION
TWU	Tokiwa Universal Wippen, with standard flange
TWUNF	Tokiwa Universal Wippen, no flange
TWUBK	Tokiwa Universal Baldwin/Knabe Wippen, no flange
TWFU	Universal Wippen Flange, 15mm
TWFA	Aeolian Type Wippen Flange, 15mm
TWFB	Baldwin Type Wippen Flange, 14mm
TWFC	Chickering Type Wippen Flange, 14.5mm
TWFK	Knabe Type Wippen Flange, 14mm
TWFMH	Mason & Hamlin Type Wippen Flange, 16.5mm
TWH - SL, SS, SXS	Heel, Slotted-type for TWUBK 20mm (SL), 16mm (SS), 12mm (SXS) <i>please specify</i>
SV-PF	Service: Pin Flanges
SV-WH	Service Glue Heels

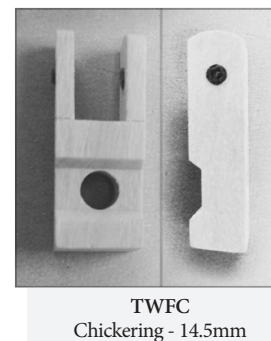

4. SELECT YOUR SERVICES

PIN FLANGES: SV-PF

GLUE HEELS: SV-WH

Call us to discuss your project needs!
(800) 326-2440

GRAND ACTION PARTS

Backactions are sold as a complete kit. Duplication of rail and assembly required.



TOKIWA Grand Action Parts

DAMPER ACTION KITS

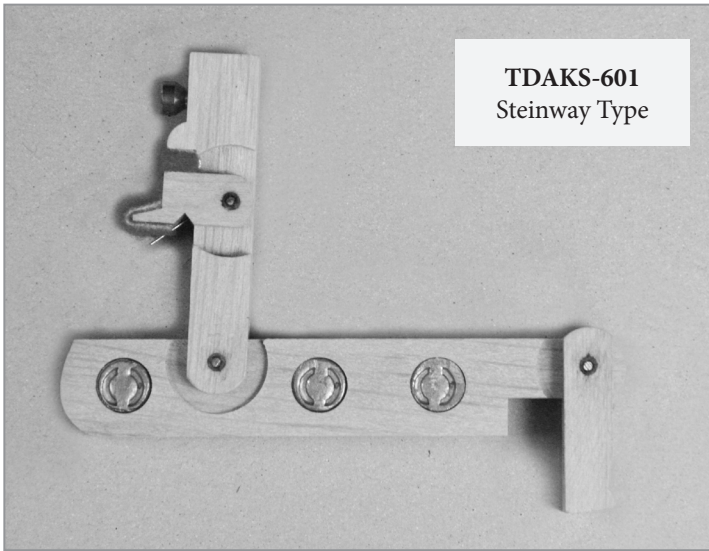

TDAKS-601
Steinway Type

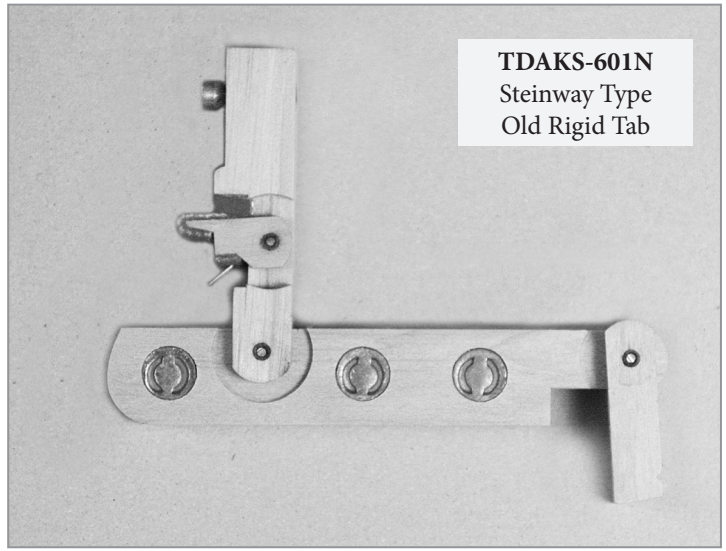

TDAKS-601N
Steinway Type
Old Rigid Tab

[Graphics may not be exact]

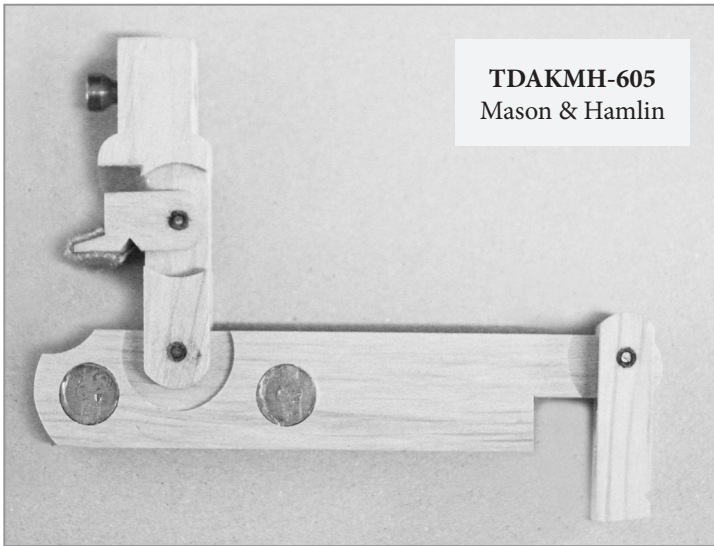

TDAKMH-605
Mason & Hamlin

**Complete Kit includes Rail,
Flange Rod, End Blocks, Felt,
Screws, Springs & Pins**

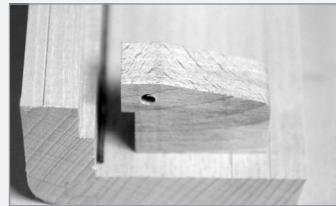

TDATFS
Top Flange only
for Steinway
601N
(sets only)

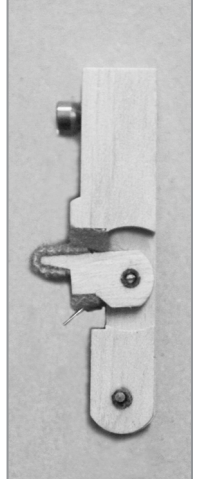

MODEL	DESCRIPTION
TDAKS-601	Damper Action Kit - Steinway type
TDAKS-601N	Damper Action Kit - Steinway type, Old Rigid Tab
TDAKMH-605	Damper Action Kit - Mason & Hamlin type
TDATFS	Damper Action Top Flange Only (for Steinway Old Rigid Tab) (sets only)

ENCORE[®] by ABEL
Brooks LTD PIANO PRODUCTS
 DAMPP-CHASER • WNG BOLDUC • TOKIWA

 (800) 326-2440
 BrooksLTDonline.com
 CUSTOM SERVICES

GRAND ACTION PARTS

WNG action parts offer an alternative to traditional wood parts.
We prehang hammers on Wessell, Nickel & Gross Parts using their specified glue.
 (800) 326-2440

WESSELL, NICKEL & GROSS Grand Action Parts

Call us to discuss your project needs! (800) 326-2440

TOP ACTION

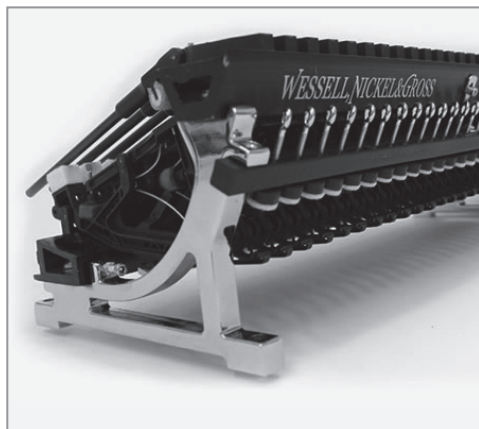

BACK ACTION

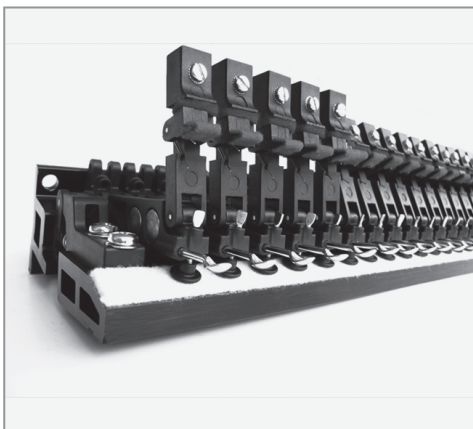

CAPSTANS

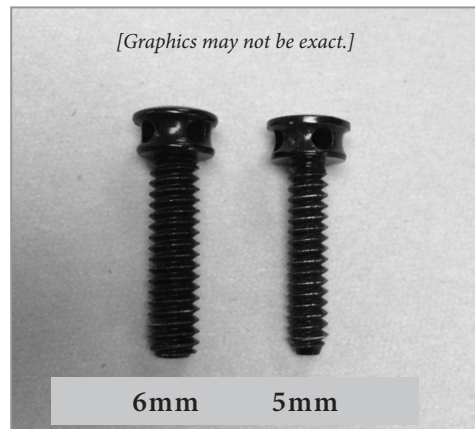

SHANKS & FLANGES



WNG ACTION PARTS

Wessell, Nickel & Gross composite material is a stable and consistent alternative to traditional wood products.

WNG	DESCRIPTION
WSF NY16	WNG Shanks & Flanges Steinway, New York (16 mm) knuckle
WSF NY16.5	WNG Shanks & Flanges Steinway, New York (16.5 mm) knuckle
WSF NY17	WNG Shanks & Flanges Steinway, New York (17 mm) knuckle
WSF C17	WNG Shanks & Flanges Mason Hamlin (17mm) knuckle
WSF-SO	WNG Shanks & flanges - Special Order
WWS	WNG Wippen, Steinway Style
WWMH	WNG Wippen, Mason Hamlin Style
WW-SO	WNG Wippen - Special Order
WC-5	WNG Capstan Standard 5mm Shank
WC-6	WNG Capstan Stienway Style 6mm Shank

PREHANG SERVICES



*For a complete list of WNG available
 Shanks & Flanges, and Wippens please contact us!
 (800) 326-2440*

UPRIGHT ACTION PARTS

Can't find what you're looking for? We're only a phone call away!

(800) 326-2440

ENCORE[®] by ABEL
Brooks LTD PIANO PRODUCERS

 (800) 326-2440
 BrooksLTDonline.com
 CUSTOM SERVICES

DAMP-CHASER • WING
 BOLDUC • TOKIWA

TOKIWA Upright Action Parts

MODEL	DESCRIPTION
TVBBR	Upright Butts - Brass Rail Type
TVBWR	Upright Butts & Flanges - Wood Rail Type
TVBY	Upright Butts & Flanges - Yamaha Type
TVBK	Upright Butts & Flanges - Kawai Type
TVFU	Upright Flange Only - Universal
TVFY	Upright Flange Only - Yamaha Type
TVFK	Upright Flange Only - Kawai Type

UPRIGHT FLANGES ONLY

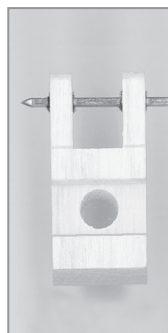

TVFU

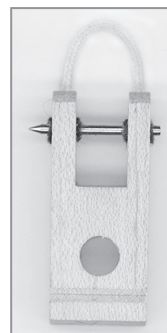

TVFK



TVFY

UPRIGHT BUTTS & FLANGES

[Graphics may not be exact.]

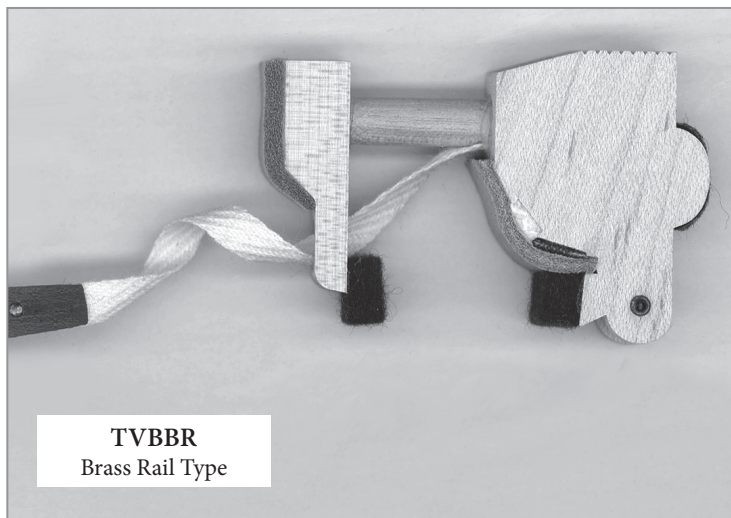

TVBBR
Brass Rail Type

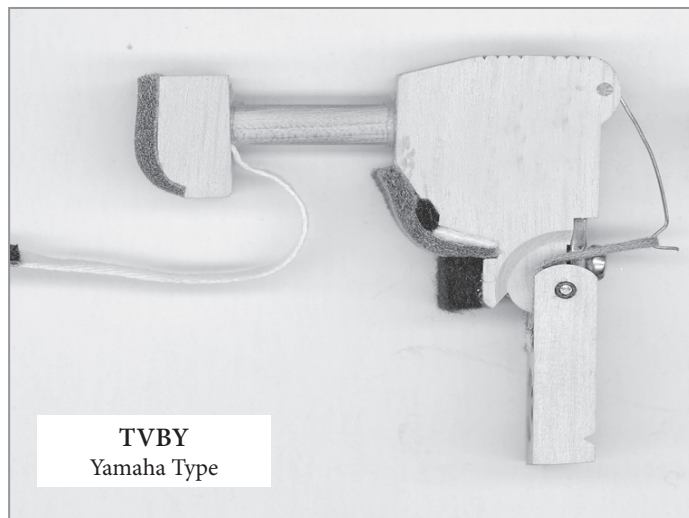

TVBY
Yamaha Type

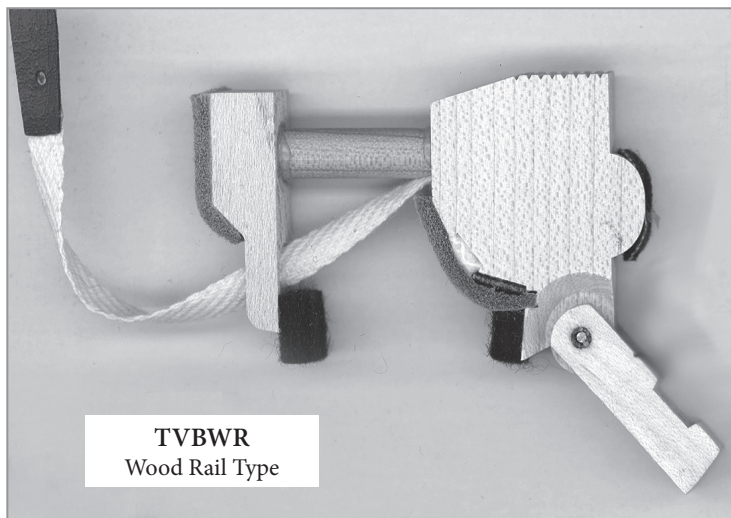

TVBWR
Wood Rail Type

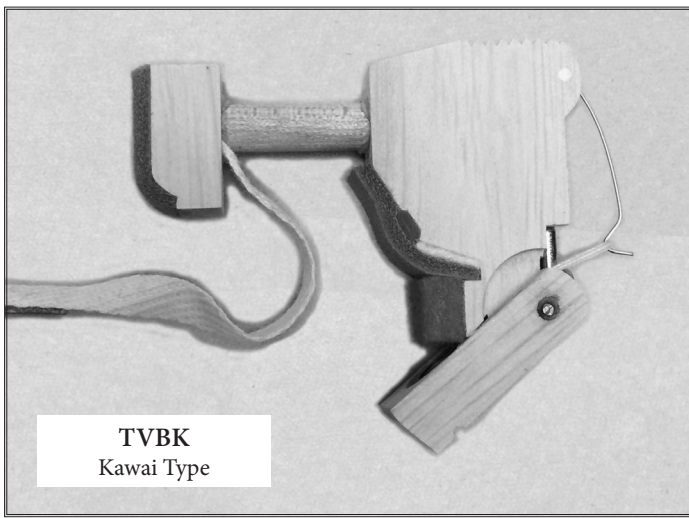

TVBK
Kawai Type

ENCORE[®] by ABEL

Brooks LTD PIANO PRODUCTS

DAMP-CHASER • WNG

BOLDUC • TOKIWA



(800) 326-2440
BrooksLTDonline.com

CUSTOM SERVICES

UPRIGHT ACTION PARTS

Can't find what you're looking for? We're only a phone call away!

(800) 326-2440

TOKIWA Steinway Type

MODEL	DESCRIPTION
TVBDFS	Steinway Type Upright Butts with Double Flanges
TVDFS	Steinway Type Upright Double Flanges Only
TVDLS	Steinway Type Upright Damper Levers (set only)
TVWS	Steinway Type Upright Wippen, F, KL, KS or V style



UPRIGHT ACTION PARTS

Replacing dampers? Check out the Upright Damper Kit TVDK on page 22
for use on your Steinway Upright action rebuild.

ENCORE[®] by ABEL

Brooks LTD
PIANO PRODUCTS



(800) 326-2440
BrooksLTDonline.com

CUSTOM SERVICES

DAMP-CHASER - WNG

BOLDUC - TOKIWA

TOKIWA Steinway Type

[Graphics may not be exact.]

TVWSKL
Steinway Type - KL Style
Upright Wippen

TVDFS Double Flanges Only

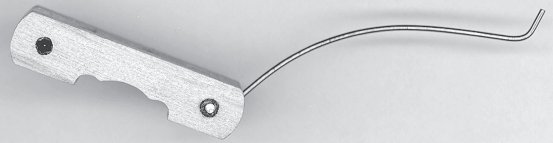
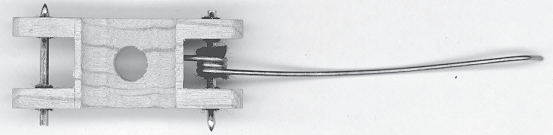

TVBDFS
Butts With Double
Flanges

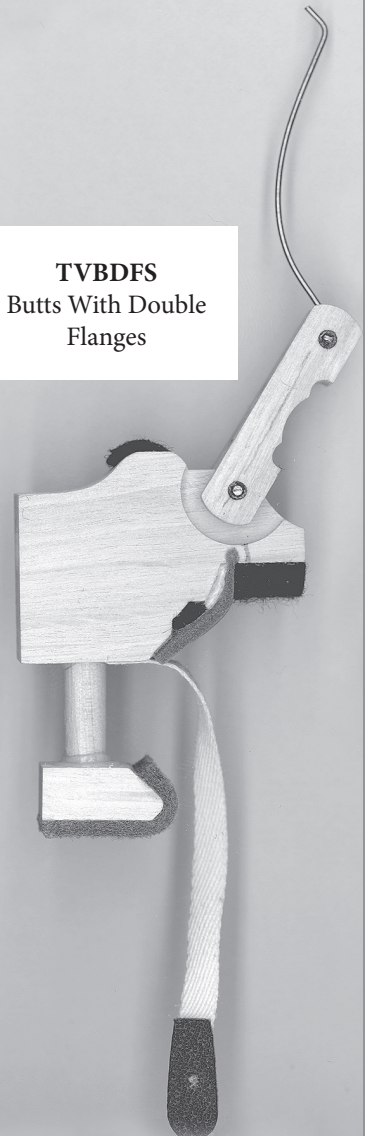

TVWSKS
Steinway Type - KS Style
Upright Wippen



ENCORE[®] by ABEL

Brooks LTD PIANO PRODUCTS

DAMP-CHASER • WNG

BOLDUC • TOKIWA



(800) 326-2440
BrooksLTDonline.com

CUSTOM SERVICES

UPRIGHT ACTION PARTS

Parts not matching exactly? Call us and we can discuss necessary modifications.
(800) 326-2440

TOKIWA Upright Action Parts

UPRIGHT WIPPENS



TVDK Upright Damper Kit

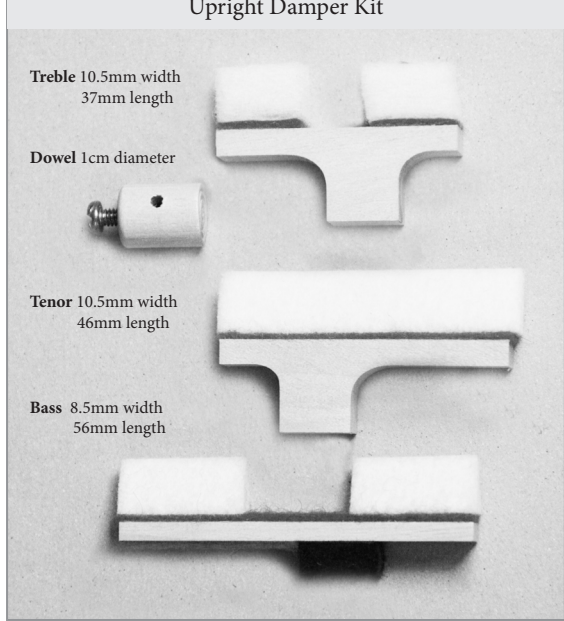

TVDL Upright Damper Lever



[Graphics are not to size.]

MODEL	DESCRIPTION
TVWDC	Upright Wippen - for Dowel Capstan
TVWST	Upright Wippen - Sticker Type
TVDF	Upright Damper Flange (set only)
TVDK	Upright Damper Kit (set only)
TVDL	Upright Damper Lever (set only)
TVSLA	Long Adjustable Sticker
TVSSA	Short Adjustable Sticker
TVSTFA	Tongue & Flange Adjustable Sticker
TVSS	Upright Spinnet Shanks

ADJUSTABLE STICKERS

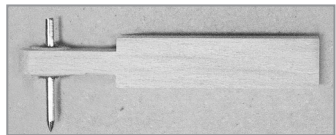

TVSSA
Short Adjustable Sticker

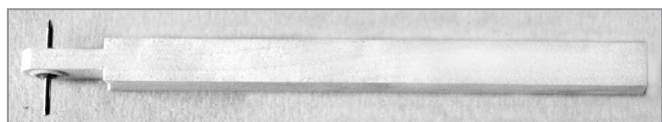

TVSLA
Long Adjustable Sticker

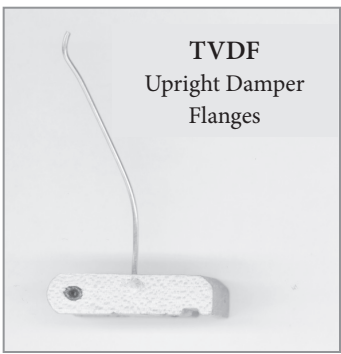
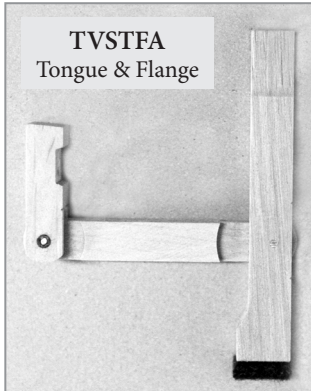

TOOLS

In stock BOLDUC Tools ship same day.



PIANOS BOLDUC Tools

BOLDUC TOUCHWEIGHT SCALE

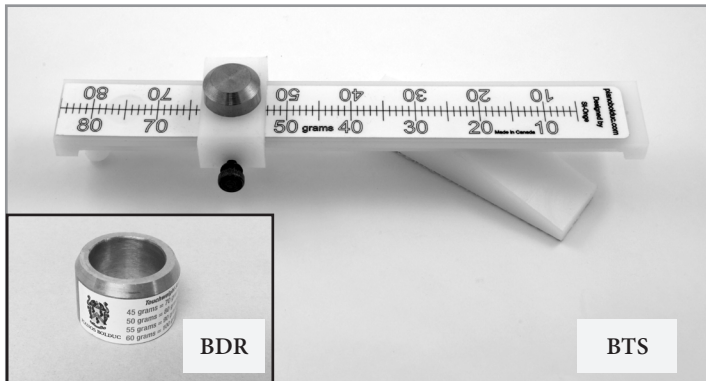

Use directly at the piano to determine existing up and down weights. Damper ring allows to measure and diagnose upright damper spring tension from the front of the key.

3-IN-ONE VOICING TOOL



Bolduc's unique 3-in-1 tool serves as a hammerhead side voicer, grand hammerhead extractor and centerpin removal and replacement tool.

MODEL	DESCRIPTION
BTS	Bolduc Touchweight Scale
BDR	Damper Ring (for use with Touchweight Scale)
BVT	Bolduc 3-in-1 Voicing Tool
BCRB	Grand Carbide Router Blade
BVPRJ	Upright Pinblock Removal Jig
BDBL	Pinblock Drill Bit, Long, 6"
BDBS	Pinblock Drill Bit, Short, 3 1/2"

GRAND CARBIDE ROUTER BLADE

Includes roller bearing guide & 4" diameter saw blade. Unique design uses stretcher bar as guide. Requires router with 1/2" diameter capacity.



UPRIGHT PINBLOCK REMOVAL JIG

Professional set up for fast, accurate removal of upright pinblocks. Machined, aluminum drilling guide and 18" x 3/8" diameter drill bit.

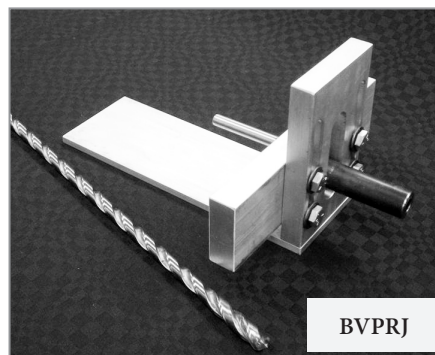

PINBLOCK DRILL BITS

Size F drill bits used to drill grand pinblock for 2/0 tuning pins available in 6" and 3 1/2" lengths.





WOOD PRODUCTS

*Pinblock, Bridge Capping, Rib Stock material and Tools stocked in-house!
In stock products ships same day if order is received by 2:30 EST M-F.*

BOLDUC Pinblock, Bridge Cap & Rib Stock

BOLDUCBLOCK PINBLOCK PANELS

*BolducBlock 5-ply pinblock is made with the highest quality, quarter-sawn, tight-grain rock maple. BolducBlock's solid maple construction makes shaping easier and the glue joint between the rim and the pinblock better and stronger.
For pinblock removal tools and drill bits see (p. 23)*

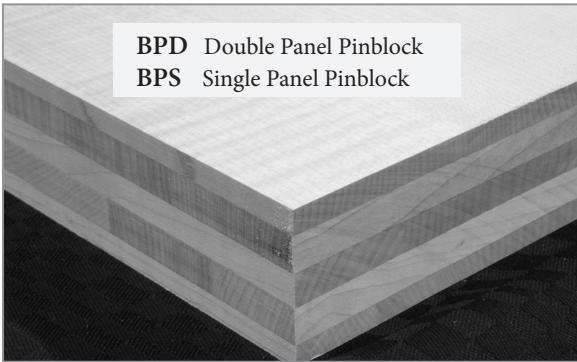

BPD Double Panel Pinblock
BPS Single Panel Pinblock

MODEL	DESCRIPTION
BPD-1$\frac{3}{8}$	BolducBlock Double Panel Pinblock, Grand, 5-Ply - 1 $\frac{3}{8}$ " x 17" x 59"
BPD-1$\frac{1}{2}$	BolducBlock Double Panel Pinblock, Grand, 5-Ply - 1 $\frac{1}{2}$ " x 17" x 59"
BPD-1$\frac{5}{8}$	BolducBlock Double Panel Pinblock, Grand, 5-Ply - 1 $\frac{5}{8}$ " x 17" x 59"
BPS	BolducBlock Single Panel Pinblock, Grand, 5-Ply - 1 $\frac{1}{2}$ " & 1 $\frac{3}{8}$ "
BPS-C	Concert Grand BolducBlock Single Panel Pinblock - 1 $\frac{5}{8}$ " x 12" x 59"
BRM	Rib Stock Material, Spruce - 1 $\frac{1}{4}$ " x 1 $\frac{1}{4}$ " x 53" - Box of 24
BCM	Bridge Capping Material - \pm 20 sq ft, 3 $\frac{1}{2}$ " or more wide, mixed lengths

BRIDGE CAPPING MATERIAL

Quarter-sawn hard rock maple, hand selected for tight grain, color quality & tolerance. Mixed lengths, box of \pm 20 sq ft.

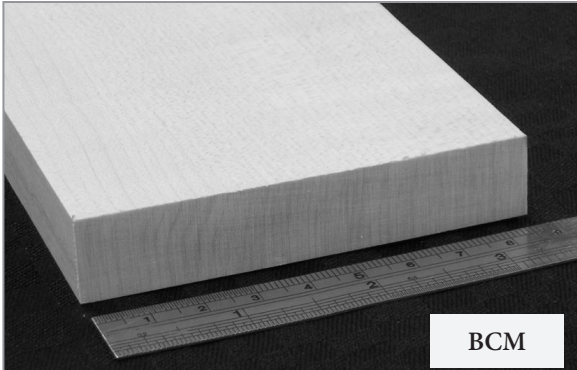

BCM

RIB STOCK MATERIAL

Quarter-sawn Eastern White Spruce, Pre-shaped. Box of 24.

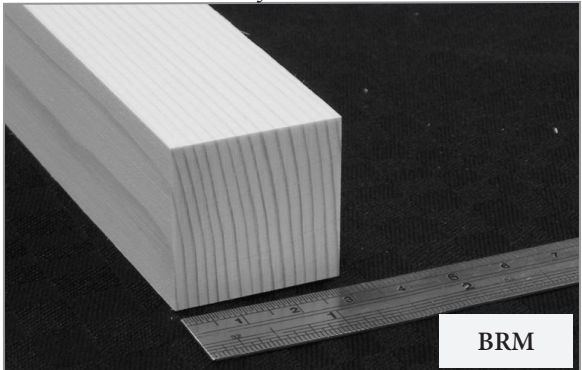

BRM

SHIPPING INFORMATION

*Ribstock, Bridge Capping and Pinblock materials are shipped directly from Brooks LTD.
In stock product will ship same day if ordered before 2:30 EST M-F.*

*Soundboard materials are shipped directly from Bolduc's facility in Canada.
Shipping & Brokerage fees apply. Please allow 4-6 weeks for delivery.*

Call (800) 326-2440 to place your order

WOOD PRODUCTS

Can't find what you're looking for? We're only a phone call away!

(800) 326-2440



BOLDUC Soundboards, Molding & Shims



BSP

BOLDUC SOUNDBOARDS

are made from the finest hand-selected Eastern White Spruce. Grain uniformity and color match ensure exceptional quality in sound and beauty. Soundboard thickness varies from $\frac{5}{16}$ " , $\frac{11}{32}$ " or $\frac{3}{8}$ " according to model.

Stock Soundboard specifications are available for

BALDWIN
MASON & HAMLIN
STEINWAY

custom specifications for all other models.

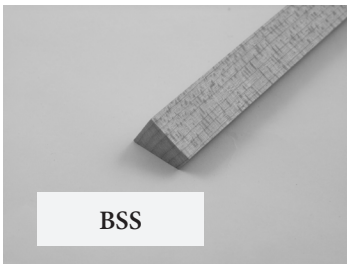

BSS

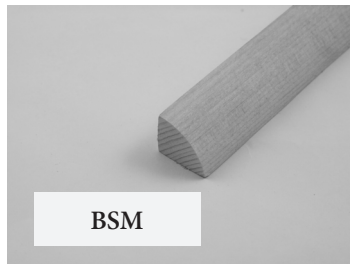

BSM

MODEL	DESCRIPTION
BSP	Soundboard Panel, Grand or Upright, all models
BSM	Soundboard Molding - $\frac{1}{2}$ " x $\frac{5}{8}$ " x 4', 5', 6' or 7'
BSS	Spruce Shims - 75cm x 12mm x 2.5, 3.5 or 4.5mm
BPCS	Precrowned Soundboard - custom specifications

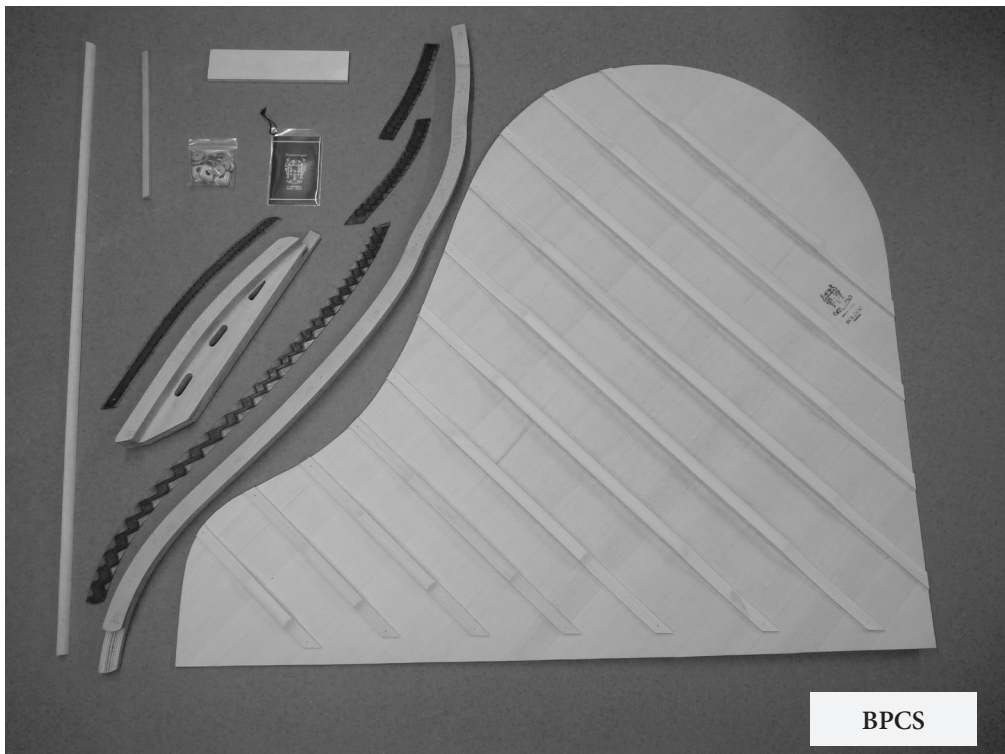

BPCS

PRECROWNED SOUNDBOARDS

Not set up for full soundboard replacement?

Have your soundboard precrowned and ribs glued at the factory with new bridge capping ready to carve .

Read more about Pianos Bolduc
www.BrooksLTDonline.com



DAMPP-CHASER Products

QUICK REFERENCE LIST

Brooks LTD carries a complete line of Dampp-Chaser Humidity Control Systems and products.

Orders placed before 2:30 pm EST for in-stock items ship same day!
800-326-2440

Piano

LIFE SAVER SYSTEM

from
DAMPP-CHASER



This Quick Reference List reflects our most frequently requested items. A complete Dampp-Chaser catalog is available for download.

GRAND AND VERTICAL SYSTEMS	
72651	G6PS 38 +SB - 4'6" to 5' 10" Grand Pianos (primary rod 36"/38w, includes 24"/25w rod)
72653	G7PS 38 +SB - 6'10" to 9' Grand Pianos (twin tanks, primary rod 36"/38w, includes 24"/25w rod)
72655	V5PS 38 +SB - Vertical System for most Upright pianos (primary rod 36" adjustable)
72674	BSV8PS - Backside 8-part system, includes Smart Bracket
<i>All systems now include a pre-installed SB Smart Bracket. All H-5 Humidistats are now calibrated at a standard 46% RH.</i>	
UNDERCOVERS	
71014	GUC/L - Grand Undercover, Large (7'4" to 9'6" Grand Pianos)
71015	GUC/M - Grand Undercover, Medium (6' to 7' Grand Pianos)
71016	GUC/BSC - Grand Undercover, Small (4'7" to 5'10" Grand Pianos & Backside Vertical)
HUMIDIFIER SUPPLIES	
50945	Pad Treatment - 7.5oz bottle, 12/pk
50944	Pad Treatment - 16oz bottle, 12/pk <i>Individual bottles also available.</i>
72891	UHP-48 - Replacement Humidifier Pads, Bulk, 48/box with 12 pk Clean Sleeves. <i>Also available in sets of 4.</i>
72890	12 Black UT liners and 1 liner for pre-Universal tall vertical tank.
50657	GHM-1 Grand or Vertical Humidifier Tank Heater Bar
59030	Replacement Watering Can
72611	Replacement Watering Can w/Reducer (for use with older systems)
72526	Watering Kit (with Can, Tube & Hardware)
FOR DEHUMIDIFIER SYSTEMS	
70639	48-50 - Dehumidifier Rod, 48"/50w <i>for grand installations</i>
70586	36-38 - Dehumidifier Rod, 36"/38w <i>for grand installations</i>
70590	24-25 - Dehumidifier Rod, 24"/25w <i>for grand installations</i>
70520	48-50A - Dehumidifier Rod, 48"/50w, Adjustable <i>for vertical installations</i>
72856	3P38A - 3/pk includes (3) H-D Humidistats and (3) 36-38A Rods, installation hardware for grand or vertical.

Learn more about Dampp-Chaser at
www.BrooksLTDonline.com

BROOKS LTD 800-326-2440



Frequently Asked Questions

SERVICES:

Q: Do I need to send samples for Hammer Duplication or Prehang Services?

A: Samples are always best for all services. If samples are not available, we can discuss necessary measurements or utilize our library of available specifications.

Q: What samples do I need to send you?

A: First and last of each section and note #71 if we are prehanging them. Please keep the hammers attached to the shanks.

Q: Can you match my wippens?

A: We carry several standard models of replacement wippens, including two Universal wippen bodies with a variety of heels and flanges, as well as access to the complete line of WNG product. If you send us a sample, we will consult with you for the best parts selection and discuss any regulation adjustments needed.

Q: Can you Prehang Upright hammers?

A: We provide an Upright Shanking Service. The cost of the maple shanks is included in the Hammer Shanking Service. We glue shanks into Upright Hammers. We do not prehang upright hammers/shank assemblies into butts; this is best done at the piano to match height variations.

Q: Do you service parts from other suppliers?

A: Yes, we will! Brooks LTD will provide all of our services on other companies' product. Call us for pricing.

Q: Can you Prehang hammers on Wessell, Nickel and Gross (WNG) parts?

A: Yes! We carry WNG shanks and flanges and are experienced prehanging hammers on them using WNG specified glue.

Q: How do you handle hammer weight and touchweight concerns?

A: Our philosophy is to restore your instrument as closely to original dimensions as possible. We work directly with you to optimize weight control and playability by selecting hammers, shanks and flanges to best suit your project. If touchweight or geometry is a concern for your instrument or you would like to alter the touchweight, we will assist you in customizing the weight of the replacement hammers and consider knuckle placement for best results.

SHIPPING:

Q: What is your typical turnaround time?

A: Our standard turnaround time for orders requiring services is four business days; from arrival of your samples. In stock product not requiring service including Dampp-Chaser Products are shipped same day if ordered by 2:30pm M-F EST

Q: What is your standard shipping method?

A: We ship via UPS within the Continental US with three day delivery. Alaska and Hawaii two day delivery and US Mail Priority Express for Canadian orders. - please call for costs.

Q: How do I receive free shipping on prepaid action part orders?

A: Action part orders prepaid by check or money order, payable to BROOKS LTD PIANO PRODUCTS are shipped via UPS Ground complimentary within the Continental U.S. Unfortunately, due to credit card processing fees the prepay option is only available with check.

ORDERS:

Q: Is there a quantity discount for Dampp-Chaser Piano Life Saver Systems?

A: There is! If you purchase three systems you will receive a 5% discount on each system cost. Additionally, we will ship them bound together as one package saving a significant amount in shipping fees.

Q: I don't see what I need in the catalog.

A: Can't find what you are looking for? Call us! We will help source the product needed to complete your project.

Q: Why don't my hammer numbers match?

A: The numbers on the sides of the hammers are for factory use only. Please count off the number of bass and treble needed and number accordingly. Spare hammers are included in your set at section ends and are marked with an X.

Q: How do I place a Bolduc Soundboard order?

A: Bolduc Soundboard orders are placed directly with us. You will receive a Sales Order with all the costs and payment terms to confirm your order.



ORDER FORM

To ensure accuracy and to expedite your order efficiently, please fill out this form completely.

NOTE: Samples are recommended and may be required for replacement action parts.

Call (800) 326-2440 M-F 830a - 330p EST to speak with a technician.

DATE: _____ PO: _____ REF: _____

CUSTOMER INFORMATION

NAME: _____ PHONE: _____

SHIPPING ADDRESS: _____

CITY, ST, ZIP: _____

EMAIL: _____

BILLING & PAYMENT INFORMATION

CHECK# _____ enclosed. AMOUNT \$ _____ Please bill my: ACCOUNT 10 DAY NET

Please charge my: VISA MC DISCOVER #

EXP: (MM/YY) V-Code: Signature: _____

BILLING ADDRESS: Same as above or: _____

CITY, ST, ZIP: _____

PROJECT INFORMATION

MAKE: _____ MODEL: _____ SERIAL#: _____

- | | | | | | |
|----------------------------|---|---|--|---|--|
| ENCORE^{wb} | <input type="checkbox"/> HAMMERS | <input type="checkbox"/> SHANKS & FLANGES | <input type="checkbox"/> WIPPENS | <input type="checkbox"/> OTHER | |
| TOKIWA | <input type="checkbox"/> SHANKS & FLANGES | <input type="checkbox"/> WIPPENS | <input type="checkbox"/> UPRIGHT BUTTS | <input type="checkbox"/> OTHER | |
| WNG | <input type="checkbox"/> SHANKS & FLANGES | <input type="checkbox"/> WIPPENS | <input type="checkbox"/> OTHER | | |
| SERVICES | <input type="checkbox"/> BORE | <input type="checkbox"/> TAPER | <input type="checkbox"/> TAIL SHAPING | <input type="checkbox"/> GRAND PREHANGING | |
| | <input type="checkbox"/> UPRIGHT SHANKING | <input type="checkbox"/> WIPPEN ASSEMBLY | <input type="checkbox"/> OTHER | | |
| BOLDUC | <input type="checkbox"/> SOUNDBOARD | <input type="checkbox"/> PINBLOCK | <input type="checkbox"/> RIB STOCK | <input type="checkbox"/> BRIDGE CAPPING | <input type="checkbox"/> OTHER |
| DAMPP-CHASER | <input type="checkbox"/> G6PS38 SB | <input type="checkbox"/> G6PS50 SB | <input type="checkbox"/> V5PS50 SB | <input type="checkbox"/> UHP-48 | <input type="checkbox"/> OTHER PRODUCT |

INSTRUCTIONS: (Please reference part # and/or preferences)

Download this and other forms online at
www.BrooksLTDonline.com

NOTES/INFORMATION



NEED HELP SELECTING ACTION PARTS?

OUR STAFF OF EXPERTS IS HERE TO ASSIST YOU!

Consistent quality, appropriate touchweight consideration, tonal quality and ease of installation are all part of what we take into account at Brooks LTD. Selection of the correct replacement parts - particularly hammers - can depend on the location of the piano, the type of music it is used for, and how often and by whom it is played, along with other varying factors. Let us help you choose the best product for your project.

Call us toll free! (800) 326-2440



Policies & Terms

At Brooks LTD, our policy is to provide the best in service and products to our customers. We are happy to work with you should your project require special needs or expedited shipping.

Brooks LTD Piano Products, LLC
152 Rt. 163, Building A ■ Uncasville, CT ■ 06382
800.326.2440 TEL ■ 860.848.8089 FAX ■ BrooksLTD@sbcglobal.net

PRICING

Brooks LTD is a wholesale distributor of piano products and supplies. We sell directly to piano technicians and rebuilders, piano dealers and universities. A current and confidential technician/dealer pricelist is available by request. We encourage you to verify pricing prior to each job, as prices are subject to change without notice.

PAYMENT TERMS

New Accounts: Pre-payment by credit card, check or money order is required for new accounts.

Pre-Paid: Pre-payment by check or money order, payable to BROOKS LTD PIANO PRODUCTS is always welcome. Return shipping by UPS Ground is complimentary within the Continental U.S. for pre-paid Action Part orders only. All other orders should include estimated shipping charges.

Credit Card: We gladly accept Visa, MasterCard or Discover. Payment by credit card is due at the time of sale.

Open Account: A 10 Day Net open account may be established for qualified customers. Open accounts are due within 10 days of invoice *by check or money order only*, and are subject to 1.5% interest per month on accounts overdue more than 30 days. Customers who repeatedly exceed 30 days overdue will be taken off open account terms.

COD: You may choose to pay COD on shipments to any U.S. destination. Additional charges apply.

SHIPPING

Most orders ship within 48 hours of receipt. Please allow 3-4 business days for prehung hammer orders and action parts requiring service. Special order and Backorders will be shipped as soon as possible.

We ship UPS within the USA, and U.S. Mail Express to Canada. Expedited shipping is available on all orders; additional charges apply. We guarantee 3-day shipping on Action Parts within the USA. In-stock Bolduc and Dampp-Chaser products ship UPS Ground. Pre-paid action part orders ship complimentary within the Continental U.S. via UPS Ground.

FOREIGN ORDERS

All foreign orders must be paid in \$US Dollars. Payment terms apply. Shipping is by U.S. Mail Express, guaranteed by the USPS in 2-5 days, unless otherwise arranged. Additional shipping charges may apply. Brokerage and customs fees are the responsibility of the receiver.

RETURNS

Standard stock items in saleable condition may be returned within 30 days of the invoice date for a full refund. After 30 days, a 10% re-stocking fee applies. Please phone for approval before returning any item. Shipping charges are the responsibility of the sender.

DAMAGED PRODUCT

If product is damaged in transit, please notify us immediately. Claims on damaged goods are not accepted after 14 days of receipt.

ORDERING & SUPPORT

Email BrooksLTD@sbcglobal.net, or call us toll free (800) 326-2440 at any time to place your order. For technical support, and to speak with our staff, please call between 8:30am and 3:30pm EST, Monday – Friday.

For additional information, to view our products and services, and to download forms and guides, visit us online!
www.BrooksLTDonline.com

Please send your order, samples or payment to ■ 152 Rt. 163, Building A ■ Uncasville, CT ■ 06382